

USER'S MANUAL
HR Series Portable Rockwell/Superficial Rockwell Hardness Tester
HBR Series Brinell & Rockwell Hardness Tester

Caution:

1. Safety goggles must be worn to prevent possible injury.
2. Gloves and the handing handle must be used during the hammer impact test.

Attention:

Check and confirm to bring the thin screw about 10-20mm up above the spiral tube before testing. If not, the force can not be loaded and the instrument may be broken.

1. Introduction

The HB-150 Portable Brinell Hardness Tester is designed following the Brinell hardness test method. The test force is controlled by a shear pin. After reading the diameter of the indentation with the reading microscope, the Brinell hardness number can be obtained from the lookup table.

The HB-150 Portable Brinell Hardness Tester has two types of application: C clamp and hammer impact (see fig.1). It is capable of testing from small to very large specimens. It is especially suitable for assemblies inconvenient to be taken to the lab and not allowed to be cut. The test can be completed in any direction to test the hardness of upper, lower and lateral part of the specimen.

The test head itself can be used as a hammer impact tester. It can perform the testing by touching one side of the work piece. Its accuracy is much higher than any other type hammer impact tester.

According to the similarity principle of Brinell hardness testing, with testing force of 1580kg, indenter diameter of 7.26mm, then $F/D^2 = 30$. The test condition of the HB tester is equivalent to the standard Brinell hardness test with 3000kgf and 10mm ball indenter.

The HB-150 Portable Brinell Hardness Tester can be widely used to test the hardness of forgings, castings, steels, nonferrous metal and its alloy products, and to test the hardness of annealed, normalizing and tempered mechanical parts.

Compared to the rebound type hardness tester, the Brinell tester has many advantages such as higher precision, fewer factors affecting accuracy and lower requirement on the surface roughness. The test result meets the requirements of most drawings without conversion and is more widely accepted in the international business.

Used as a self-product the operation of HB-1 hammer impact Brinell hardness tester can be referred to hammer impact part of HB-150.

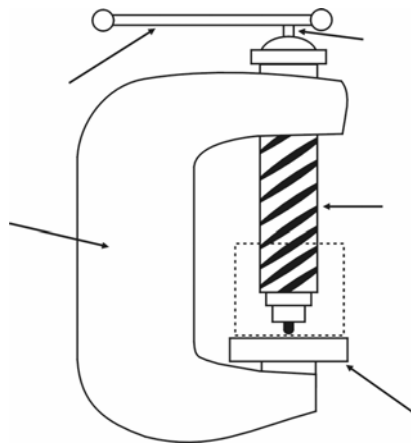

Fig. 1 Portable Brinell Hardness Tester



Fig. 2 Hammer Impact Hardness Tester

2. Principle and Structure



(a)

- 1 — C clamp
- 2 — Spiral tube
- 3 — Thin screw
- 4 — Handle
- 5 — Anvil

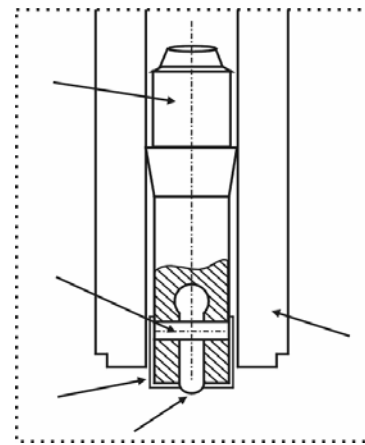

(b)

- 6 — Test head (Indenter holder)
- 7 — Rubber protective cap
- 8 — Shear pin
- 9 — Indenter

The structure of the instrument is shown in Fig.3.

The instrument is composed of C Clamp, spiral tube, test head, thin screw, handle, anvil and the force transmission system in the spiral tube. See Fig.3 (a).

The spiral tube is used for clamping the specimen and the thin screw is for applying test force. See Fig.3 (b).

The hammer impact Brinell hardness tester is composed of the test head which is taken off from the spiral tube, impact cylinder, holding handle and hammer. See Fig.2.

The principle of the instrument and inside structure of the test head are shown in Fig.4.

A shear pin is placed in the horizontal hole on the test head. The indenter is pushed into the bottom hole and its top touches shear pin. The test head is placed into the spiral tube (C clamp) or impact cylinder (hammer impact).

When the test force is applied on top of the test head, the force is transmitted to the indenter through the shear pin which presses indenter against the specimen. As soon as the test force reaches 1580kg, the shear pin is cut into three segments by the cutting system comprising the test head and the indenter. The excessive force will not be transmitted to the indenter as it withdraws into bottom hole of the test head, and a round indentation will remain on the surface of the specimen.

The indentation diameter is measured with a reading microscope, and the Brinell hardness number can be obtained from the lookup table.

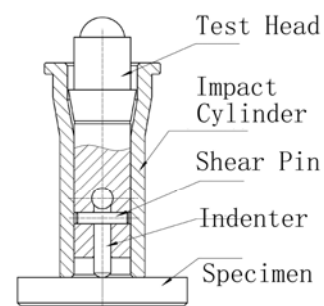

Fig. 4 Principle of the instrument

3. Technical Parameters

Test force:	1580kg;
Tolerance of test force:	<0.5%;
Accuracy:	C clamp In accordance with ISO6506 Hammer impact <5%
Indenter:	Φ7.26mm steel spherical surface indenter (range: 100-400HB) Φ4.0mm carbide spherical surface indenter (Optional) (range: 400-650HB)
Opening size (H×D):	150mm×100mm
Net weight:	C clamp: 4.2kg Hammer impact: 0.8kg

4. Operation Instructions

4.1 Instructions for the C Clamp Tester

The portable hardness testers includes the C Clamp, which is a kind of static test.

4.1.1 Indenter Selection. According to the expected hardness of the testing piece, choose the suitable indenter. When testing the softer metal with the hardness lower than 400HB, choose the steel spherical surface indenter with a diameter of 7.26mm; when testing hard steel materials with the hardness higher than 400HB, choose the carbide spherical surface indenter with a diameter of 4.0mm.

4.1.2 Anvil Selection. Choose an appropriate anvil to fit the shape and size of the specimen, and install it in the bottom of the C Clamp. The flat anvil is for flat blocks or sheets; the V anvil is for cylinders; the dome anvil is for curled sheets and pipes. The right anvil should provide a firm support for the specimen, and there should be no slipping or distortion when the force is applied.

4.1.3 Put a shear pin into the horizontal hole of the test head. Push the indenter into the bottom hole of the test head with the spherical surface out and make sure it contacts the shear pin. Cover the bottom of the test head with the rubber protective cap, in order that the cap contacts the bottom of the test head closely, the indenter should come out from the central hole of protective cap. The purposes of the cap are to protect the surface of the specimen and prevent shear pin from spattering.

4.1.4 Install the test head into the bottom of the spiral tube.

4.1.5 Check and confirm to bring the thin screw which is under the handle about 10-20mm up above the spiral tube. If not, operate according to Step 4.1.9.

4.1.6 Place the specimen in the opening of the C Clamp. Make sure the back of the specimen completely contacts the anvil, and the indenter is perpendicular to the tested surface of the specimen. Rotate the handle clockwise, drive the spiral tube down and clamp the tester on the specimen. After the indenter reaches the specimen, continue rotating the handle to drive the thin screw down until a breaking sound is heard, which means the shear pin is broken and the force application is completed.

4.1.7 Rotate the handle counterclockwise and raise the spiral tube.

4.1.8 Take out the test head from the lower part of the spiral tube and take off the rubber protective cap. Remove the broken shear pin and push the indenter out with the pin removal tool.

4.1.9 Hold the lower part of the spiral tube, rotate the handle counterclockwise and raise the thin screw up about 10-20mm above the spiral tube. Do make sure to raise the thin screw up after each test.

4.1.10 Use the reading microscope to read the indentation diameter in two perpendicular directions. Refer to Section 4.4 for the instructions of the reading microscope.

4.1.11 Check Appendix A or Appendix B with the average indentation diameter to get the Brinell hardness value.

4.2 Instructions for the Hammer Impact Tester

The hammer impact tester does not include the C Clamp. It only includes the test head, impact cylinder, holding handle and hammer. The hardness testing by hammer impact tester is a kind of dynamic hardness testing. The hardness testing by hammer impact tester is a kind of dynamic hardness testing.

4.2.1 Put a shear pin into the horizontal hole of the test head. Push the indenter into the bottom hole of the test head with the spherical surface out and make sure it contacts the shear pin.

4.2.2 Place the test head into impact cylinder.

4.2.3 Put the handle on the specimen. Put the impact cylinder into the handle, and make sure the bottom of the impact cylinder rest firmly on the specimen.

4.2.4 Use the flat side of a 3 lb (1.5kg) hammer to apply a sharp blow on top of the test head. The shear pin must be broken at the first blow. If the pin is not broken, another blow must be applied in order to remove the pin, and the result must be ignored.

4.2.5 Take out the test head and remove the broken shear pin with the pin removal tool. Push the indenter outward off the hole of the shear pin. If the shear pin is not completely broken off, the test should be considered as invalid. Install a new shear pin and test again. Be sure to break off the shear pin completely.

4.2.6 The dynamic test with a bigger force may result in an elliptic indentation. The diameter of the indentation must be measured in at least two directions. Use the smallest diameter as the valid one to check Appendix C, D or E for the Brinell hardness value.

4.3 Usage of the Reading Microscope

4.3.1 Look into the ocular with enough light and turn the barrel dial to make the vertical lens line aligned with the “0” scale of the horizontal line. Meanwhile the long scale mark should rest on “0” scale of the barrel dial.

4.3.2 Put the reading microscope on the test piece to locate the indentation in the centre of the viewing field of the microscope. Move the microscope to make the vertical line tangential to the left edge of the indentation. Press the bottom of the reading microscope, turn the barrel dial to make the vertical line tangential to the right edge of the indentation.

4.3.3 Read the integral part (mm) of the indentation diameter from the horizontal scale mark, then read the 2-digit decimal part of the indentation diameter from the barrel dial.

4.3.3 When the vertical line is aligned with the “0” scale mark of the horizontal line, but the “0” scale mark of the barrel dial is not aligned with the long scale mark, it means the microscope is inaccurate. Adjustment should be made as follow:

- a. Make the vertical lens line aligned with the “0” scale mark of the horizontal line.

- b. Unscrew the three screws on the barrel dial.
- c. Make the “0” scale mark on the barrel dial exactly aligned with the long scale mark.
- d. Fasten the three screws.

5. Verification

The Brinell standard hardness block is used to calibrate the Brinell tester. The test result on the test block should be close to the hardness of testing pieces.

Impact on testing blocks by hardness tester and get indentation, measuring the average diameter value of indentation by microscope, then get the hardness value after check appendix. The error of this tester is the difference between this value and the value of testing block.

6. Cautions and Tips

6.1 When testing with the C Clamp, the thin screw must be brought about 20mm up before testing. If not, the thin screw cannot drive the test force on the specimen and it may be damaged.

6.2 Do not disassemble the spiral tube. The tester will be damaged permanently and the warranty will be void.

6.3 When the hardness of specimen is greater than 400HB, the carbide indenter must be used.

6.4 Indenters are normal wear items and are not covered by the warranty. The carbide indenter is more brittle and more easily broken than the steel indenter.

6.5 To protect the specimen surface from the impact cylinder, a cardboard with a hole bigger than indenter can be placed between the impact cylinder and the specimen.

6.6 Wear safety goggles and gloves to prevent possible injury.

7. Factors Affecting Testing Accuracy

7.1 Specimen Surface

The surface of the specimen should be smooth and clean for the best accuracy. The rough surface makes the indentation edge blurry and affects the measurement of the indentation diameters which will increase the dispersity of the test result. The rough surface can also reduce the specimen's resistance against the pressing indenter which will result in a lower Brinell hardness value. Use a sand paper or polish machine to polish the part to be tested for better accuracy. If the oxide coating, decarbonization layer, dust or dirt remains on the specimen surface, the hardness testing will be invalid. Remove those things before testing.

7.2 Supporting of the specimen

Carefully clean the bearing surface of the specimen to ensure that the impurities or dirt like oxide coating, grease and dust can not be found between the back side of the specimen

and the supporting anvil.

Choose the proper anvil, proper testing surface and the bearing surface to ensure that the specimen is firmly supported without sliding or deformation when the test force is applied.

7.3 Impact Effect of Hammer Impact Tester

The specimen may move under the test force when the hammer impact tester is being used which will affect the testing result.

When testing with the hammer impact hardness tester, loading and unloading of the test force is finished in an instant, and the dwell time of the greatest test force does not reach the set time of the ordinary Brinell hardness testing. This will affect the testing result.

As above-mentioned, the operator should regularly make comparison tests with the standard Brinell hardness testers in order to ensure the accuracy of the testing result. The static (C Clamp) tester can be used as the comparison tester to verify the test result of the hammer impact hardness tester.

The accuracy of the hammer impact Brinell hardness tester can be lowered by impact effect, so the prior selection should be static (C Clamp) testing if the specimen size allows.

8. Factors Affecting Testing Accuracy

Brinell hardness test can reflect the average mechanical properties of a large region of the specimen, so there is a close relation between the Brinell hardness and other mechanical properties of materials, especially tensile strength.

The approximate conversion equation is:

$$\sigma_b = K \cdot HB$$

in this equation: σ_b is the tensile strength value in MPa;

K is a constant depending on the material.

The tensile strength of materials can be obtained indirect by testing the Brinell hardness with its approximate value obtained by conversion, which is of great importance in practical production by both increasing work efficiency and saving material as well.

The conversion of hardness-tensile strength of some metallic materials is shown below:

Material	Brinell Hardness Value	Approximate Conversion
Steel	125~175	$\sigma_b \approx 3.43HB$ (MPa)
	>175	$\sigma_b \approx 3.63HB$ (MPa)
Cast aluminum alloy		$\sigma_b \approx 2.6HB$ (MPa)
annealed brass, bronze		$\sigma_b \approx 5.5HB$ (MPa)
Brass, bronze after being cold-processed		$\sigma_b \approx 4.0HB$ (MPa)

9. Standard Package

Standard package of PHB-150 Brinell Hardness Tester	Standard package of PHB-1 Brinell Hardness Tester
1 Tester	1 Test head
1 steel ball indenter	1 Impact cylinder
1 Flat anvil	1 Indenter
1 V anvil	1 Holding handle
1 Brinell standard hardness block	1 Pack of shear pins (250 pieces)
1 Holding handle	1 Reading microscope 20x
1 Pin removal tool	1 Brinell standard hardness block
	1 Pin removal tool
1 Pack of shear pins (250 pieces)	1 Carrying case
1 Impact cylinder	1 Manual
1 Reading microscope 20x	
2 Rubber protective caps	
1 Carrying case	
1 Manual	

10. Optional Accessories and Spare Parts

Steel ball indenter
Carbide ball indenter
Brinell standard hardness block
Test head
Shear pins (a pack of 250pcs)
Hemispherical spot anvil (used for testing tubing or curled specimens)
Small flat anvil (used for testing small specimens)
40x reading microscope (used for $\Phi 4.0$ mm carbide indenter)
3 lb hammer

Appendix A :Indentation—Brinell Hardness Table 1

C Clamp Tester Steel Indenter ϕ 7.26mm							
Indentation Diameter mm	Hardness HB	Indentation Diameter mm	Hardness HB	Indentation Diameter mm	Hardness HB	Indentation Diameter mm	Hardness HB
2.00	480.0	2.35	349.0	2.70	264.0	3.05	204.0
2.01	475.6	2.36	346.0	2.71	262.0	3.06	202.6
2.02	471.2	2.37	343.0	2.72	260.0	3.07	201.2
2.03	466.8	2.38	340.0	2.73	258.0	3.08	199.8
2.04	462.4	2.39	337.0	2.74	256.0	3.09	198.4
2.05	458.0	2.40	334.0	2.75	254.0	3.10	197.0
2.06	454.0	2.41	331.4	2.76	252.2	3.11	195.6
2.07	450.0	2.42	328.8	2.77	250.4	3.12	194.2
2.08	446.0	2.43	326.2	2.78	248.6	3.13	192.8
2.09	442.0	2.44	323.6	2.79	246.8	3.14	191.4
2.10	438.0	2.45	321.0	2.80	245.0	3.15	190.0
2.11	434.2	2.46	318.4	2.81	243.2	3.16	188.8
2.12	430.4	2.47	315.8	2.82	241.4	3.17	187.6
2.13	426.6	2.48	313.2	2.83	239.6	3.18	186.4
2.14	422.8	2.49	310.6	2.84	237.8	3.19	185.2
2.15	419.0	2.50	308.0	2.85	236.0	3.20	184.0
2.16	415.4	2.51	305.8	2.86	234.4	3.21	182.8
2.17	411.8	2.52	303.6	2.87	232.8	3.22	181.6
2.18	408.2	2.53	301.4	2.88	231.2	3.23	180.4
2.19	404.6	2.54	299.2	2.89	229.6	3.24	179.2
2.20	401.0	2.55	297.0	2.90	228.0	3.25	178.0
2.21	397.4	2.56	294.6	2.91	226.4	3.26	176.8
2.22	393.8	2.57	292.2	2.92	224.8	3.27	175.6
2.23	390.2	2.58	289.8	2.93	223.2	3.28	174.4
2.24	386.6	2.59	287.4	2.94	221.6	3.29	173.2
2.25	383.0	2.60	285.0	2.95	220.0	3.30	172.0
2.26	379.4	2.61	282.8	2.96	218.4	3.31	171.0
2.27	375.8	2.62	280.6	2.97	216.8	3.32	170.0
2.28	372.2	2.63	278.4	2.98	215.2	3.33	169.0
2.29	368.6	2.64	276.2	2.99	213.6	3.34	168.0
2.30	365.0	2.65	274.0	3.00	212.0	3.35	167.0
2.31	361.8	2.66	272.0	3.01	210.4	3.36	166.0
2.32	358.6	2.67	270.0	3.02	208.8	3.37	165.0
2.33	355.4	2.68	268.0	3.03	207.2	3.38	164.0
2.34	352.2	2.69	266.0	3.04	205.6	3.39	163.0

C Clamp Tester Steel Indenter ϕ 7.26mm							
Indentation Diameter mm	Hardness HB	Indentation Diameter mm	Hardness HB	Indentation Diameter mm	Hardness HB	Indentation Diameter mm	Hardness HB
3.40	162.0	3.59	143.0	3.78	127.6	3.97	112.4
3.41	161.0	3.60	142.0	3.79	126.8	3.98	111.6
3.42	160.0	3.61	141.2	3.80	126.0	3.99	110.8
3.43	159.0	3.62	140.4	3.81	125.2	4.00	110.0
3.44	158.0	3.63	139.6	3.82	124.4	4.01	109.2
3.45	157.0	3.64	138.8	3.83	123.6	4.02	108.4
3.46	156.0	3.65	138.0	3.84	122.8	4.03	107.6
3.47	155.0	3.66	137.2	3.85	122.0	4.04	106.8
3.48	154.0	3.67	136.4	3.86	121.2	4.05	106.0
3.49	153.0	3.68	135.6	3.87	120.4	4.06	105.4
3.50	152.0	3.69	134.8	3.88	119.6	4.07	104.8
3.51	151.0	3.70	134.0	3.89	118.8	4.08	104.2
3.52	150.0	3.71	133.2	3.90	118.0	4.09	103.6
3.53	149.0	3.72	132.4	3.91	117.2	4.10	103.0
3.54	148.0	3.73	131.6	3.92	116.4	4.11	102.4
3.55	147.0	3.74	130.8	3.93	115.6	4.12	101.8
3.56	146.0	3.75	130.0	3.94	114.8	4.13	101.2
3.57	145.0	3.76	129.2	3.95	114.0	4.14	100.6
3.58	144.0	3.77	128.4	3.96	113.2	4.15	100.0

Appendix B: Indentation—Brinell Hardness Table 2

C Clamp Tester—Carbide Indenter ϕ 4mm							
Diameter	HB	Diameter	HB	Diameter	HB	Diameter	HB
1.45	742.0	1.71	614.0	1.97	471.9	2.23	366.8
1.46	735.2	1.72	608.3	1.98	466.9	2.24	363.4
1.47	728.4	1.73	602.5	1.99	462.0	2.25	360.0
1.48	721.6	1.74	596.8	2.00	457.0	2.26	356.8
1.49	714.8	1.75	591.0	2.01	452.8	2.27	353.6
1.50	708.0	1.76	584.9	2.02	448.5	2.28	350.4
1.51	701.4	1.77	578.8	2.03	444.3	2.29	347.2
1.52	694.8	1.78	572.8	2.04	440.0	2.30	344.0
1.53	688.2	1.79	566.7	2.05	435.8	2.31	340.8
1.54	681.6	1.80	560.6	2.06	431.6	2.32	337.6
1.55	675.0	1.81	555.5	2.07	427.5	2.33	334.4
1.56	673.5	1.82	550.4	2.08	423.3	2.34	331.2
1.57	672.0	1.83	545.4	2.09	419.2	2.35	328.0
1.58	668.9	1.84	540.3	2.10	415.0	2.36	325.5
1.59	665.7	1.85	535.2	2.11	411.0	2.37	323.0
1.60	662.6	1.86	529.4	2.12	407.0	2.38	320.4
1.61	658.9	1.87	523.7	2.13	403.0	2.39	317.9
1.62	655.2	1.88	517.9	2.14	399.0	2.40	315.4
1.63	651.4	1.89	512.2	2.15	395.0	2.41	312.6
1.64	647.7	1.90	506.4	2.16	391.4	2.42	309.7
1.65	644.0	1.91	501.5	2.17	387.8	2.43	306.9
1.66	639.2	1.92	496.6	2.18	384.2	2.44	304.0
1.67	634.3	1.93	491.6	2.19	380.6	2.45	301.2
1.68	629.5	1.94	486.7	2.20	377.0		
1.69	624.6	1.95	481.8	2.21	373.6		
1.70	619.8	1.96	476.8	2.22	370.2		

Appendix C: Indentation—Brinell Hardness Table 3

Hammer Impact—Steel Ball Indenter ϕ 7.26mm—for Steel							
Diameter	HB	Diameter	HB	Diameter	HB	Diameter	HB
2.05	484.0	2.49	315.4	2.93	217.6	3.37	155.2
2.06	479.2	2.50	312.0	2.94	215.8	3.38	153.8
2.07	474.4	2.51	309.0	2.95	214.0	3.39	152.4
2.08	469.6	2.52	306.0	2.96	212.4	3.40	151.0
2.09	464.8	2.53	303.0	2.97	210.8	3.41	149.8
2.10	460.0	2.54	300.0	2.98	209.2	3.42	148.6
2.11	455.8	2.55	297.0	2.99	207.6	3.43	147.4
2.12	451.6	2.56	294.2	3.00	206.0	3.44	146.2
2.13	447.4	2.57	291.4	3.01	204.4	3.45	145.0
2.14	443.2	2.58	288.6	3.02	202.8	3.46	143.6
2.15	439.0	2.59	285.8	3.03	201.2	3.47	142.2
2.16	435.0	2.60	283.0	3.04	199.6	3.48	140.8
2.17	431.0	2.61	280.8	3.05	198.0	3.49	139.4
2.18	427.0	2.62	278.6	3.06	196.6	3.50	138.0
2.19	423.0	2.63	276.4	3.07	195.2	3.51	136.8
2.20	419.0	2.64	274.2	3.08	193.8	3.52	135.6
2.21	415.2	2.65	272.0	3.09	192.4	3.53	134.4
2.22	411.4	2.66	270.0	3.10	191.0	3.54	133.2
2.23	407.6	2.67	268.0	3.11	189.6	3.55	132.0
2.24	403.8	2.68	266.0	3.12	188.2	3.56	130.6
2.25	400.0	2.69	264.0	3.13	186.8	3.57	129.2
2.26	396.4	2.70	262.0	3.14	185.4	3.58	127.8
2.27	392.8	2.71	260.0	3.15	184.0	3.59	126.4
2.28	389.2	2.72	258.0	3.16	182.6	3.60	125.0
2.29	385.6	2.73	256.0	3.17	181.2	3.61	123.8
2.30	382.0	2.74	254.0	3.18	179.8	3.62	122.6
2.31	378.4	2.75	252.0	3.19	178.4	3.63	121.4
2.32	374.8	2.76	250.0	3.20	177.0	3.64	120.2
2.33	371.2	2.77	248.0	3.21	175.8	3.65	119.0
2.34	367.6	2.78	246.0	3.22	174.6	3.66	117.6
2.35	364.0	2.79	244.0	3.23	173.4	3.67	116.2
2.36	360.4	2.80	242.0	3.24	172.2	3.68	114.8
2.37	356.8	2.81	240.0	3.25	171.0	3.69	113.4
2.38	353.2	2.82	238.0	3.26	169.6	3.70	112.0
2.39	349.6	2.83	236.0	3.27	168.2	3.71	110.8
2.40	346.0	2.84	234.0	3.28	166.8	3.72	109.6
2.41	342.6	2.85	232.0	3.29	165.4	3.73	108.4
2.42	339.2	2.86	230.2	3.30	164.0	3.74	107.2
2.43	335.8	2.87	228.4	3.31	162.8	3.75	106.0
2.44	332.4	2.88	226.6	3.32	161.6	3.76	104.6
2.45	329.0	2.89	224.8	3.33	160.4	3.77	103.2
2.46	325.6	2.90	223.0	3.34	159.2	3.78	101.8
2.47	322.2	2.91	221.2	3.35	158.0	3.79	100.4
2.48	318.8	2.92	219.4	3.36	156.6	3.80	99.0

Appendix D: Indentation—Brinell Hardness Table 4

Hammer Impact—Steel Ball Indenter ϕ 7.26mm—for Cast Iron							
Diameter	HB	Diameter	HB	Diameter	HB	Diameter	HB
2.50	308.0	2.84	237.8	3.18	186.4	3.52	150.0
2.51	305.8	2.85	236.0	3.19	185.2	3.53	149.0
2.52	303.6	2.86	234.4	3.20	184.0	3.54	148.0
2.53	301.4	2.87	232.8	3.21	182.8	3.55	147.0
2.54	299.2	2.88	231.2	3.22	181.6	3.56	146.0
2.55	297.0	2.89	229.6	3.23	180.4	3.57	145.0
2.56	294.6	2.90	228.0	3.24	179.2	3.58	144.0
2.57	292.2	2.91	226.4	3.25	178.0	3.59	143.0
2.58	289.8	2.92	224.8	3.26	176.8	3.60	142.0
2.59	287.4	2.93	223.2	3.27	175.6	3.61	141.2
2.60	285.0	2.94	221.6	3.28	174.4	3.62	140.4
2.61	282.8	2.95	220.0	3.29	173.2	3.63	139.6
2.62	280.6	2.96	218.4	3.30	172.0	3.64	138.8
2.63	278.4	2.97	216.8	3.31	171.0	3.65	138.0
2.64	276.2	2.98	215.2	3.32	170.0	3.66	137.2
2.65	274.0	2.99	213.6	3.33	169.0	3.67	136.4
2.66	272.0	3.00	212.0	3.34	168.0	3.68	135.6
2.67	270.0	3.01	210.4	3.35	167.0	3.69	134.8
2.68	268.0	3.02	208.8	3.36	166.0	3.70	134.0
2.69	266.0	3.03	207.2	3.37	165.0	3.71	133.2
2.70	264.0	3.04	205.6	3.38	164.0	3.72	132.4
2.71	262.0	3.05	204.0	3.39	163.0	3.73	131.6
2.72	260.0	3.06	202.6	3.40	162.0	3.74	130.8
2.73	258.0	3.07	201.2	3.41	161.0	3.75	130.0
2.74	256.0	3.08	199.8	3.42	160.0	3.76	129.2
2.75	254.0	3.09	198.4	3.43	159.0	3.77	128.4
2.76	252.2	3.10	197.0	3.44	158.0	3.78	127.6
2.77	250.4	3.11	195.6	3.45	157.0	3.79	126.8
2.78	248.6	3.12	194.2	3.46	156.0	3.80	126.0
2.79	246.8	3.13	192.8	3.47	155.0	3.81	125.2
2.80	245.0	3.14	191.4	3.48	154.0	3.82	124.4
2.81	243.2	3.15	190.0	3.49	153.0	3.83	123.6
2.82	241.4	3.16	188.8	3.50	152.0	3.84	122.8
2.83	239.6	3.17	187.6	3.51	151.0	3.85	122.0

Appendix E: Indentation—Brinell Hardness Table 5

Hammer Impact—Carbide Indenter ϕ 4mm							
Diameter	HB	Diameter	HB	Diameter	HB	Diameter	HB
1.55	742.0	1.79	596.0	2.03	462.9	2.27	359.4
1.56		1.80	589.8	2.04	457.8	2.28	355.6
1.57		1.81	585.0	2.05	452.8	2.29	351.8
1.58		1.82	580.2	2.06	447.8	2.30	348.0
1.59		1.83	575.4	2.07	442.9	2.31	344.6
1.60	708.0	1.84	570.6	2.08	437.9	2.32	341.2
1.61		1.85	565.8	2.09	433.0	2.33	337.8
1.62		1.86	559.3	2.10	428.0	2.34	334.4
1.63		1.87	552.8	2.11	423.7	2.35	331.0
1.64		1.88	546.4	2.12	419.4	2.36	327.3
1.65	673.0	1.89	539.9	2.13	415.2	2.37	323.6
1.66		1.90	533.4	2.14	410.9	2.38	319.8
1.67		1.91	528.1	2.15	406.6	2.39	316.1
1.68		1.92	522.8	2.16	402.1	2.40	312.4
1.69		1.93	517.4	2.17	397.6	2.41	309.5
1.70	639.8	1.94	512.1	2.18	393.0	2.42	306.6
1.71	636.0	1.95	506.8	2.19	388.5	2.43	303.8
1.72	632.2	1.96	501.0	2.20	384.0	2.44	300.9
1.73	628.4	1.97	495.3	2.21	380.6	2.45	298.0
1.74	624.6	1.98	489.5	2.22	377.2	2.46	294.6
1.75	620.8	1.99	483.8	2.23	373.8	2.47	291.3
1.76	614.6	2.00	478.0	2.24	370.4	2.48	287.9
1.77	608.4	2.01	473.0	2.25	367.0	2.49	284.6
1.78	602.2	2.02	467.9	2.26	363.2	2.50	281.2

Appendix F Conversion Value of Hardness and Strength of Ferrous Metal

Table A conversion value of hardness and strength of all kinds of steels

Hardness								Tensile strength σ_p /MPa								
Rockwell		Superficial Rockwell			Vickers	Brinell (F/D ² =30)		Carbon steel	Chrome steel	Chrome-vanadium steel	Chrome nickel steel	chrome molybdenum steel	chromium nickel molybdenum steel	chromansil	Super high strength steel	Stainless steel
HRC	HRA	HR15N	HR30N	HR45N	HV	HBS	HBW									
20.0	60.2	68.8	40.7	19.2	226	225		774	742	736	782	747		781		740
20.5	60.4	69.0	41.2	19.8	228	227		784	751	744	787	753		788		749
21.0	60.7	69.3	41.7	20.4	230	229		793	760	753	792	760		794		758
21.5	61.0	69.5	42.2	21.0	233	232		803	769	761	797	767		801		767
22.0	61.2	69.8	42.6	21.5	235	234		813	799	770	803	774		809		777
22.5	61.5	70.0	43.1	22.1	238	237		823	788	779	809	781		816		786
23.0	61.7	70.3	43.6	22.7	241	240		833	798	788	815	789		824		796
23.5	62.0	70.6	44.0	23.3	244	242		843	808	797	822	797		832		806
24.0	62.2	70.8	44.5	23.9	247	245		854	818	807	829	805		840		816
24.5	62.5	71.1	45.0	24.5	250	248		864	828	816	836	813		848		826
25.0	62.8	71.4	45.5	25.1	253	251		875	838	826	843	822		856		837
25.5	63.0	71.6	45.9	25.7	256	254		886	848	837	851	831	850	865		847
26.0	63.3	71.9	46.4	26.3	259	257		897	859	847	859	840	859	874		858
26.5	63.5	72.2	46.9	26.9	262	260		908	870	858	867	850	869	883		868
27.0	63.8	72.4	47.3	27.5	266	263		919	880	869	876	860	870	893		879
27.5	64.0	72.7	47.8	28.1	269	266		930	891	880	885	870	890	902		890
28.0	64.3	73.0	48.3	28.7	273	269		942	902	892	894	880	901	912		901
28.5	64.6	73.3	48.7	29.3	276	273		954	914	903	904	891	912	922		913
29.0	64.8	73.5	49.2	29.9	280	276		965	925	915	914	902	923	933		924
29.5	65.1	73.8	49.7	30.5	284	280		977	937	928	924	913	935	943		936
30.0	65.3	74.1	50.2	31.1	288	283		989	948	940	935	924	947	954		947
30.5	65.6	74.4	50.6	31.7	292	287		1002	960	953	946	936	959	965		959
31.0	65.8	74.7	51.1	32.3	296	291		1014	972	966	957	948	972	977		971
31.5	66.1	74.9	51.6	32.9	300	294		1027	984	980	969	961	985	989		983
32.0	66.4	75.2	52.0	33.5	304	298		1039	996	993	981	974	999	1001		996
32.5	66.6	75.5	52.5	34.1	308	302		1052	1009	1007	994	987	1012	1013		1008
33.0	66.9	75.8	53.0	34.7	313	306		1065	1022	1022	1007	1001	1027	1026		1021
33.5	67.1	76.1	53.4	35.3	317	310		1078	1034	1036	1020	1015	1041	1039		1034
34.0	67.4	76.4	53.9	35.9	321	314		1092	1048	1051	1034	1029	1056	1052		1047
34.5	67.7	76.7	54.4	36.5	326	318		1105	1064	1067	1048	1043	1071	1066		1060
35.0	67.9	77.0	54.8	37.0	331	323		1119	1074	1082	1063	1058	1087	1079		1074
35.5	67.9	77.0	55.3	37.6	335	327		1133	1088	1098	1078	1074	1103	1094		1087

Hardness								Tensile strength σ_p /MPa								
Rockwell		Superficial Rockwell			Vickers	Brinell (F/D ² =30)		Carbon steel	Chrome steel	Chrome-vanadium steel	Chrome nickel steel	chrome molybdenum steel	chromium nickel molybdenum steel	chromansil	Super high strength steel	Stainless steel
HRC	HRA	HR15N	HR30N	HR45N	HV	HBS	HBW									
36.0	68.4	77.5	55.8	38.2	340	332		1147	1102	1114	1093	1090	1119	1108		1101
36.5	68.7	77.8	56.2	38.8	345	336		1162	1116	1131	1109	1106	1136	1123		1116
37.0	69.0	78.1	56.7	39.4	350	341		1117	1131	1148	1125	1122	1153	1139		1130
37.5	69.2	78.4	57.2	40.0	355	345		1192	1146	1165	1142	1139	1171	1155		1145
38.0	69.5	78.7	57.6	40.6	360	350		1207	1161	1183	1159	1157	1189	1171		1161
38.5	69.7	79.0	58.1	41.2	365	355		1222	1176	1201	1177	1174	1207	1187	1170	1176
39.0	70.0	79.3	58.6	41.8	371	360		1238	1192	1219	1195	1192	1226	1204	1195	1193
39.5	70.3	79.6	59.0	42.4	376	365		1254	1208	1238	1214	1211	1245	1222	1219	1209
40.0	70.5	79.9	59.5	43.0	381	370	370	1271	1225	1257	1233	1230	1265	1240	1243	1226
40.5	70.8	80.2	60.0	43.6	387	375	375	1288	1242	1276	1252	1249	1285	1258	1267	1244
41.0	71.1	80.5	60.4	44.2	393	380	381	1305	1260	1296	1273	1269	1306	1277	1290	1262
41.5	71.3	80.8	60.9	44.8	398	385	386	1322	1278	1317	1293	1289	1327	1296	1313	1280
42.0	71.6	81.1	61.3	45.4	404	391	392	1340	1296	1337	1314	1310	1348	1316	1336	1299
42.5	71.8	81.4	61.8	45.9	410	396	397	1359	1315	1358	1336	1331	1370	1336	1359	1319
43.0	72.1	81.7	62.3	46.5	416	401	403	1378	1335	1380	1358	1353	1392	1357	1381	1339
43.5	72.4	82.0	62.7	47.1	422	407	409	1397	1355	1401	1380	1375	1415	1378	1404	1361
44.0	72.6	82.3	63.2	47.7	428	413	415	1417	1376	1424	1404	1397	1439	1400	1427	1383
44.5	72.9	82.6	63.6	48.3	435	418	422	1438	1398	1446	1427	1420	1462	1422	1450	1405
45.0	73.2	82.9	64.1	48.9	441	424	428	1459	1420	1469	1451	1444	1487	1445	1473	1429
45.5	73.4	83.2	64.6	49.5	448	430	435	1481	1444	1493	1476	1468	1512	1469	1496	1453
46.0	73.7	83.5	65.0	50.1	454	436	441	1503	1468	1517	1502	1492	1537	1493	1520	1479
46.5	73.9	83.7	65.5	50.7	461	442	448	1526	1493	1541	1527	1517	1563	1517	1544	1505
47.0	74.2	84.0	65.9	51.2	468	449	455	1550	1519	1566	1554	1542	1589	1543	1569	1533
47.5	74.5	84.3	66.4	51.8	475		463	1575	1546	1591	1581	1568	1616	1569	1594	1562
48.0	74.7	84.6	66.8	52.4	482		470	1600	1574	1617	1608	1595	1643	1595	1620	1592
48.5	75.0	84.9	67.3	53.0	489		478	1626	1603	1643	1636	1622	1671	1623	1646	1623
49.0	75.3	85.2	67.7	53.6	497		486	1653	1633	1670	1665	1649	1699	1651	1674	1655
49.5	75.5	85.5	68.2	54.2	504		494	1681	1665	1697	1695	1677	1728	1679	1702	1689
50.0	75.8	85.7	68.6	54.7	512		502	1710	1698	1724	1724	1706	1758	1709	1731	1725
50.5	76.1	86.0	69.1	55.3	520		510		1732	1752	1755	1735	1788	1739	1761	
51.0	76.3	86.3	69.5	55.9	527		518		1768	1780	1786	1764	1819	1770	1792	
51.5	76.6	86.6	70.0	56.5	535		527		1806	1809	1818	1794	1850	1801	1824	
52.0	76.9	86.8	70.4	57.1	544		535		1845	1839	1850	1825	1881	1834	1857	
52.5	77.1	87.1	70.9	57.6	552		544			1869	1883	1856	1914	1867	1892	

Hardness								Tensile strength σ_p /MPa								
Rockwell		Superficial Rockwell			Vickers	Brinell (F/D ² =30)		Carbon steel	Chrome steel	Chrome-vanadium steel	Chrome nickel steel	chrome molybdenum steel	chromium nickel molybdenum steel	chromansil	Super high strength steel	Stainless steel
HRC	HRA	HR15N	HR30N	HR45N	HV	HBS	HBW									
53.0	77.4	87.4	71.3	58.3	561		552			1899	1917	1888	1947	1901	1929	
53.5	77.7	87.6	71.8	58.8	569		561			1930	1951			1936	1966	
54.0	77.9	87.9	72.2	59.4	578		569			1961	1986			1971	2006	
54.5	78.2	88.1	72.6	59.9	587		577			1993	2022			2008	2047	
55.0	78.5	88.4	73.1	60.5	596		585			2026	2058			2045	2090	
55.5	78.7	88.6	73.5	61.1	606		593								2135	
56.0	79.0	88.9	73.9	61.7	615		601								2181	
56.5	79.3	89.1	74.4	62.2	625		608								2230	
57.0	79.5	89.4	74.8	62.8	635		616								2281	
57.5	79.8	89.6	75.2	63.4	645		622								2334	
58.0	80.1	89.8	75.6	63.9	655		628								2390	
58.5	80.3	90.0	76.1	64.5	666		634								2448	
59.0	80.6	90.2	76.5	65.1	676		639								2509	
59.5	80.9	90.4	76.9	65.6	687		643								2572	
60.0	81.2	90.6	77.3	66.2	698		647								2639	
60.5	81.4	90.8	77.7	66.8	710		650									
61.0	81.7	91.0	78.1	67.3	721											
61.5	82.0	91.2	78.6	67.9	733											
62.0	82.2	91.4	79.0	68.4	745											
62.5	82.5	91.5	79.4	69.0	757											
63.0	82.8	91.7	79.8	69.5	770											
63.5	83.1	91.8	80.2	70.1	782											
64.0	83.3	91.9	80.6	70.6	795											
64.5	83.6	92.1	81.0	71.2	809											
65.0	83.9	92.2	81.3	71.7	822											
65.5	84.1				836											
66.0	84.4				850											
66.5	84.7				865											
67.0	85.0				879											
67.5	85.2				894											
68.0	85.5				909											

Table B Conversion value of hardness and strength of mild steels

Hardness							Tensile strength of mild steels σ_b /MPa
Rockwell	Superficial Rockwell			Vickers	Brinell		
HRB	HR15T	HR30T	HR45T	HV	HBS		
					F/D ² =10	F/D ² =30	
60.0	80.4	56.1	30.4	105	102		375
60.5	80.5	56.4	30.9	105	102		377
61.0	80.7	56.7	31.4	106	103		379
61.5	80.8	57.1	31.9	107	103		381
62.0	80.9	57.4	32.4	108	104		382
62.5	81.1	57.7	32.9	108	104		384
63.0	81.2	58.0	33.5	109	105		386
63.5	81.4	58.3	34.0	110	105		388
64.0	81.5	58.7	34.5	110	106		390
64.5	81.6	59.0	35.0	111	106		393
65.0	81.8	59.3	35.5	112	107		395
65.5	81.9	59.6	36.1	113	107		397
66.0	82.1	59.9	36.6	114	108		399
66.5	82.2	60.3	37.1	115	108		402
67.0	82.3	60.6	37.6	115	109		404
67.5	82.5	60.9	38.1	116	110		407
68.0	82.6	61.2	38.6	117	110		409
68.5	82.7	61.5	39.2	118	111		412
69.0	82.9	61.9	39.7	119	112		415
69.5	83.0	62.2	40.2	120	112		418
70.0	83.2	62.5	40.7	121	113		421
70.5	83.3	62.8	41.2	122	114		424
71.0	83.4	63.1	41.7	123	115		427
71.5	83.6	63.5	42.3	124	115		430
72.0	83.7	63.8	42.8	125	116		433
72.5	83.9	64.1	43.3	126	117		437
73.0	84.0	64.4	43.8	128	118		440
73.5	84.1	64.7	44.3	129	119		444
74.0	84.3	65.1	44.8	130	120		447
74.5	84.4	65.4	45.4	131	121		451
75.0	84.5	65.7	45.9	132	122		455
75.5	84.7	66.0	46.4	134	123		459
76.0	84.8	66.3	46.9	135	124		463
76.5	85.0	66.6	47.4	136	125		467

Hardness							Tensile strength of mild steels σ_b /MPa
Rockwell	Superficial Rockwell			Vickers	Brinell		
HRB	HR15T	HR30T	HR45T	HV	HBS		
					F/D ² =10	F/D ² =30	
77.0	85.1	67.0	47.9	138	126		471
77.5	85.2	67.3	48.5	139	127		475
78.0	85.4	67.6	49.0	140	128		480
78.5	85.5	67.9	49.5	142	129		484
79.0	85.7	68.2	50.0	143	130		489
79.5	85.8	68.6	50.5	145	132		493
80.0	85.9	68.9	51.0	146	133		498
80.5	86.1	69.2	51.6	148	134		503
81.0	86.2	69.5	52.1	149	136		508
81.5	86.3	69.8	52.6	151	137		513
82.0	86.5	70.2	53.1	152	138		518
82.5	86.6	70.5	53.6	154	140		523
83.0	86.8	70.8	54.1	156		152	529
83.5	86.9	71.1	54.7	157		154	534
84.0	87.0	71.4	55.2	159		155	540
84.5	87.2	71.8	55.7	161		156	546
85.0	87.3	72.1	56.2	163		158	551
85.5	87.5	72.4	56.7	165		159	557
86.0	87.6	72.7	57.2	166		161	563
86.5	87.7	73.0	57.8	168		163	570
87.0	87.9	73.4	58.3	170		164	576
87.5	88.0	73.7	58.8	172		166	582
88.0	88.1	74.0	59.3	174		168	589
88.5	88.3	74.3	59.8	176		170	596
89.0	88.4	74.6	60.3	178		172	603
89.5	88.6	75.0	60.9	180		174	609
90.0	88.7	75.3	61.4	183		176	617
90.5	88.8	75.6	61.9	185		178	624
91.0	89.0	75.9	62.4	187		180	631
91.5	89.1	76.2	62.9	189		182	639
92.0	89.3	76.6	63.4	191		184	646
92.5	89.4	76.9	64.0	194		187	654
93.0	89.5	77.2	64.5	196		189	662
93.5	89.7	77.5	65.0	199		192	670

Hardness							Tensile strength of mild steels σ_b /MPa
Rockwell	Superficial Rockwell			Vickers	Brinell		
HRB	HR15T	HR30T	HR45T	HV	HBS		
					F/D ² =10	F/D ² =30	
94.0	89.8	77.8	65.5	201		195	678
94.5	89.9	78.2	66.0	203		197	686
95.0	90.1	78.5	66.5	206		200	695
95.5	90.2	78.8	67.1	208		203	703
96.0	90.4	79.1	67.6	211		206	712
96.5	90.5	79.4	68.1	214		209	721
97.0	90.6	79.8	68.6	216		212	730
97.5	90.8	80.1	69.1	219		215	739
98.0	90.9	80.4	69.6	222		218	749
98.5	91.1	80.7	70.2	225		222	758
99.0	91.2	81.0	70.7	227		226	768
99.5	91.3	81.4	71.2	230		229	778
100.0	91.5	81.7	71.7	233		232	788